

PMA1350

High Current, Power Inductors



Description

- AEC-Q200 qualified
- Halogen Free
- 155°C maximum total temperature operation
- 13.8x12.9x 5.0mm max. surface mount package
- Powder iron core material
- Magnetically shielded, low EMI
- High current carrying capacity, Low core losses
- RoHS compliant

Application

Engine and Powertrain Systems

- Electric pumps, motor control and auxiliaries
- Powertrain control module (PCU)
- Engine Control unit (ECU)

Body electronics

- Central body control module
- Vehicle control system
- Headlamps, tail lamps and interior lighting
- Electronic stability control system (ESC)

Environmental Data

- Storage temperature range: -55°C to +155 °C
- Operating temperature range: -55°C to +155°C
- (ambient plus self-temperature rise)
- Solder reflow temperature: J-STD-020D compliant

Ordering Information

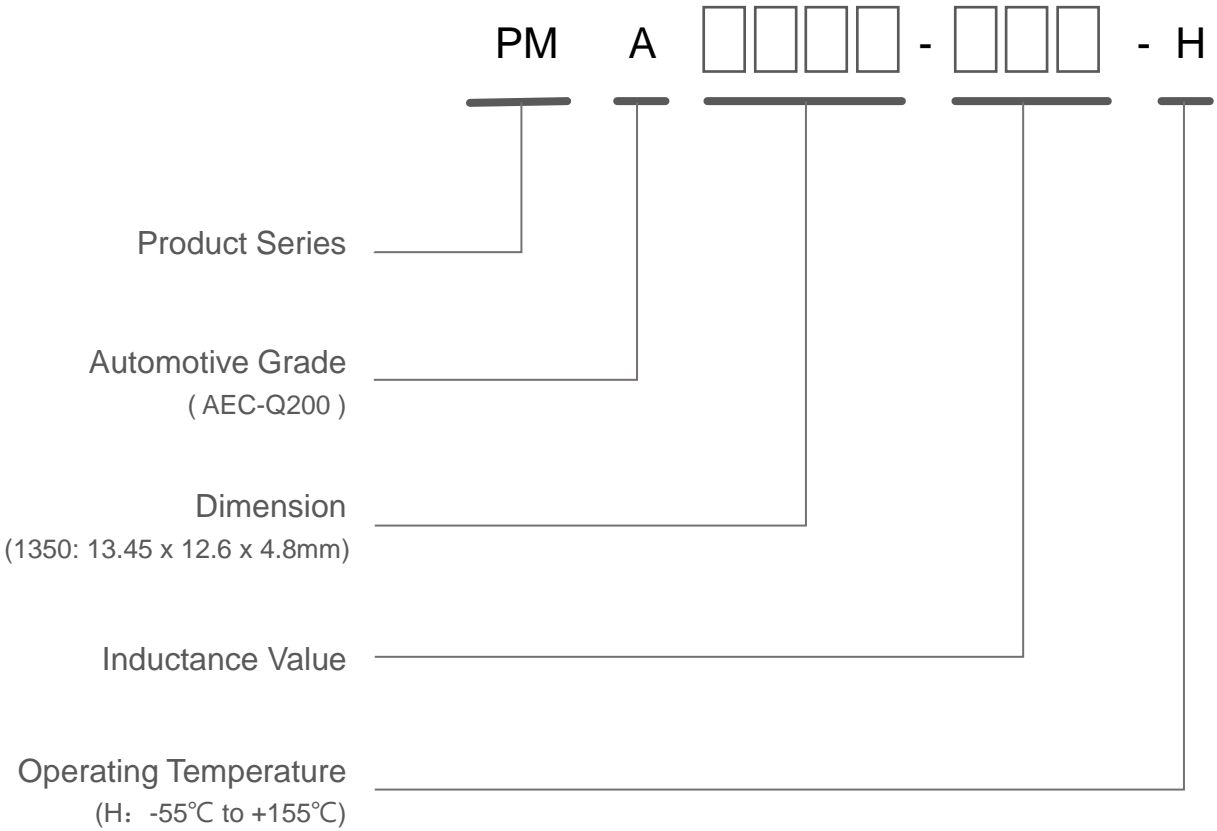

Product Specifications

Part No.	Inductance	DC Resistance		Heating Rating Current	Saturation Current
	L0 (μH)	DCR (mΩ)		Idc (A)	Isat (A)
	± 20 %, 100kHz, 1V	TYP.	MAX.	TYP.	TYP.
PMA1350-R10-H	0.1	0.33	0.38	54.0	100.0
PMA1350-R22-H	0.22	0.54	0.62	48.0	85.0
PMA1350-R33-H	0.33	0.60	0.69	46.0	66.0
PMA1350-R47-H	0.47	0.78	0.90	43.0	64.0
PMA1350-R56-H	0.56	1.15	1.32	36.0	62.0
PMA1350-R68-H	0.68	1.17	1.35	36.0	60.0
PMA1350-R82-H	0.82	1.4	1.6	31.0	45.0
PMA1350-1R0-H	1.0	1.8	2.0	26.0	39.5
PMA1350-1R5-H	1.5	2.7	3.1	23.0	39.0
PMA1350-1R8-H	1.8	3.3	3.8	21.5	35.0
PMA1350-2R2-H	2.2	4.0	4.6	21.0	28.0
PMA1350-3R3-H	3.3	6.0	6.9	16.0	24.0
PMA1350-4R7-H	4.7	8.0	9.2	14.0	20.5
PMA1350-5R6-H	5.6	10.5	12.0	12.0	20.0
PMA1350-6R0-H	6.0	11.0	12.5	12.0	19.5
PMA1350-6R8-H	6.8	12.0	13.5	11.5	16.5
PMA1350-7R8-H	7.8	15.0	17.0	10.0	16.0
PMA1350-8R2-H	8.2	16.0	18.5	9.0	15.0
PMA1350-100-H	10.0	18.5	21.5	8.5	14.0
PMA1350-120-H	12.0	19.5	22.5	8.2	13.5
PMA1350-150-H	15.0	22.5	26.0	7.8	10.0
PMA1350-220-H	22.0	34.5	39.5	6.5	8.2
PMA1350-330-H	33.0	50.0	57.5	5.5	7.5

Notes

1. All test data is referenced to 25 °C ambient temperature
2. Operating temperature range - 55 °C to + 155 °C
3. Idc(A):DC current (A) that will cause an approximate ΔT of 40 °C(reference ambient temperature is 25 °C)
4. Isat(A):DC current (A) that will cause L0 to drop approximately 30 %
5. The part temperature (ambient + temp rise) should not exceed 155 °C under worst case operating conditions.
Circuit design, component placement, PWB trace size and thickness, airflow and other cooling provisions all affect the part temperature. Part temperature should be verified in the end application.

Inductance and temperature rise vs. current

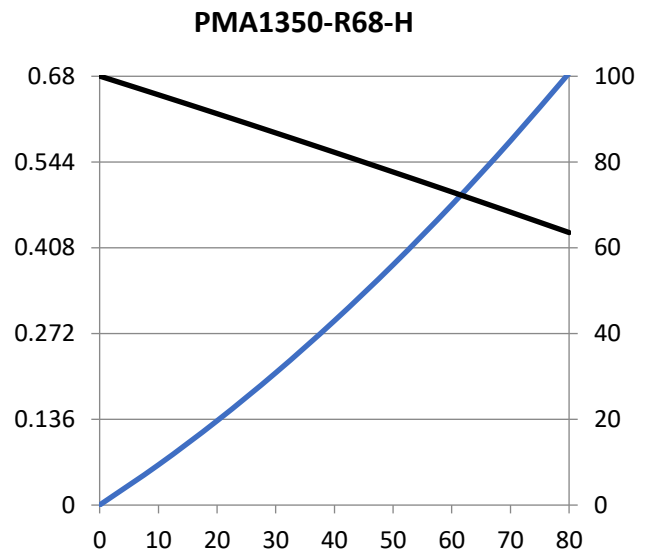
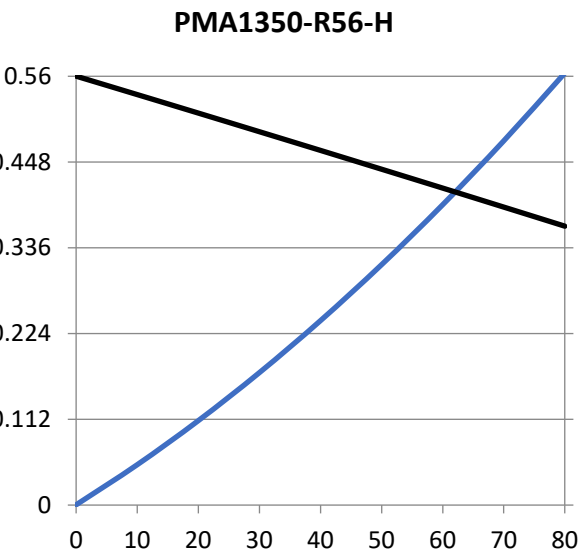
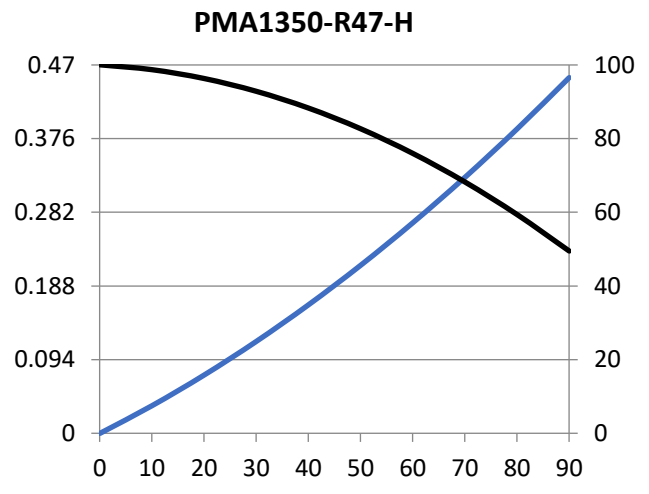
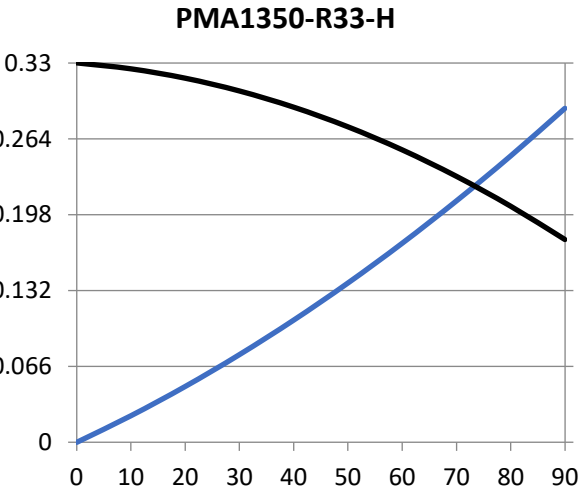
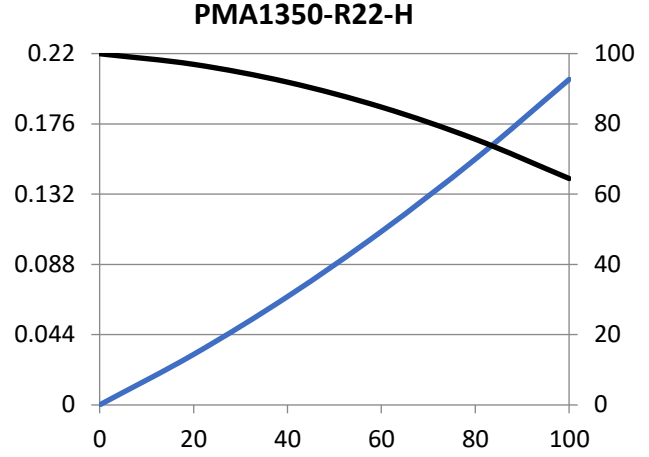
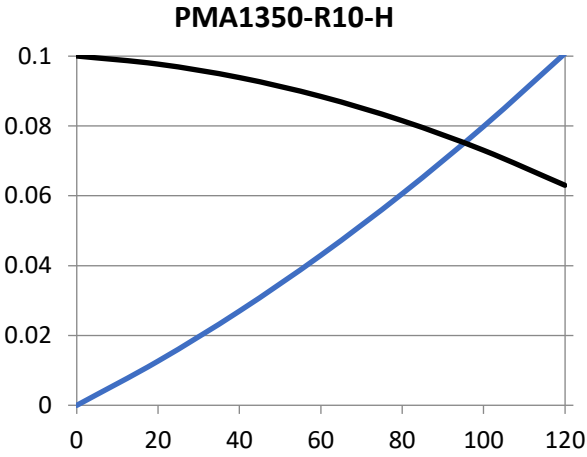

Inductance and temperature rise vs. current

PMA1350-R82-H

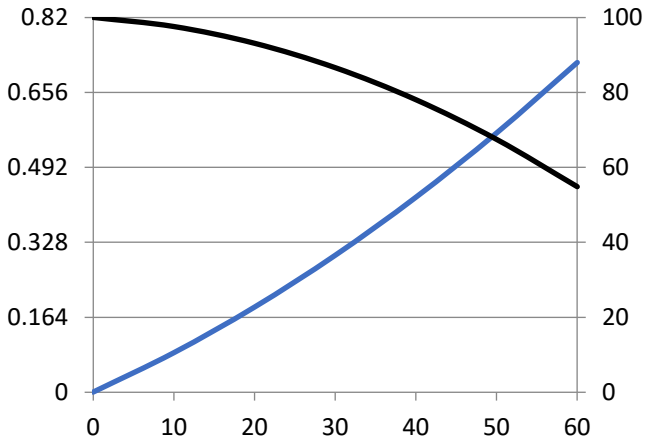

PMA1350-1R0-H

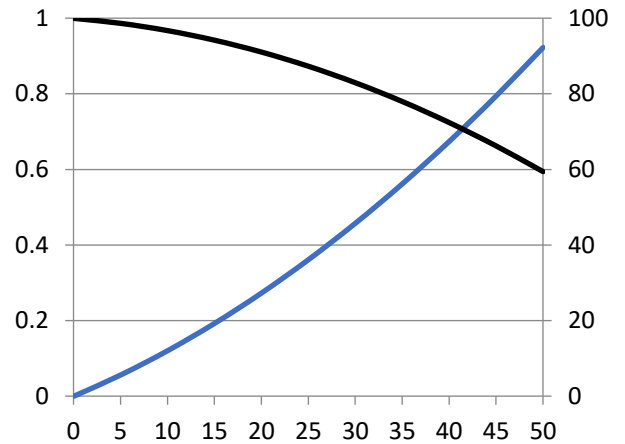

PMA1350-1R5-H

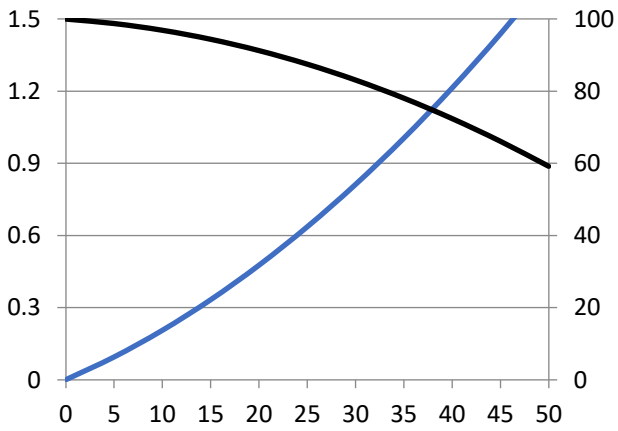

PMA1350-1R8-H

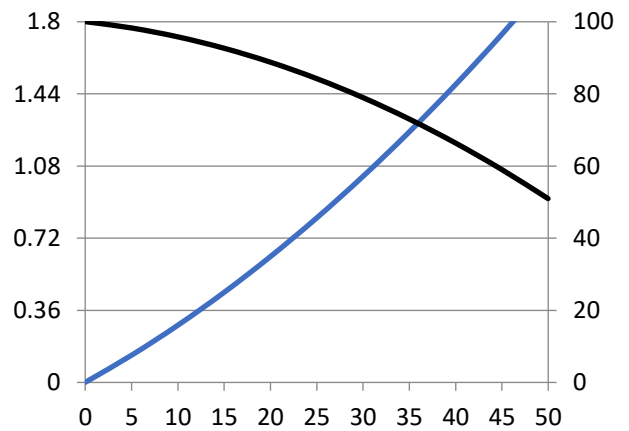

PMA1350-2R2-H

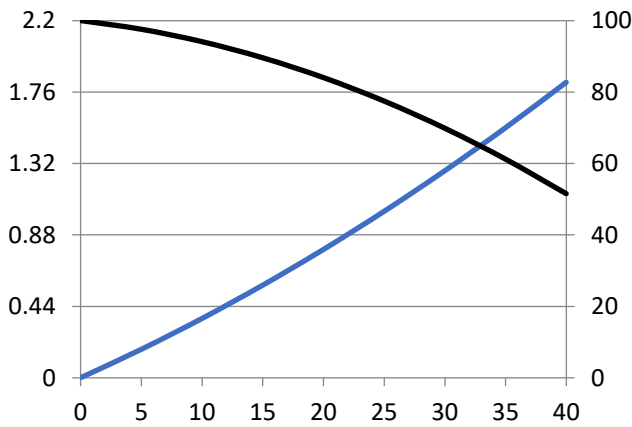

PMA1350-3R3-H

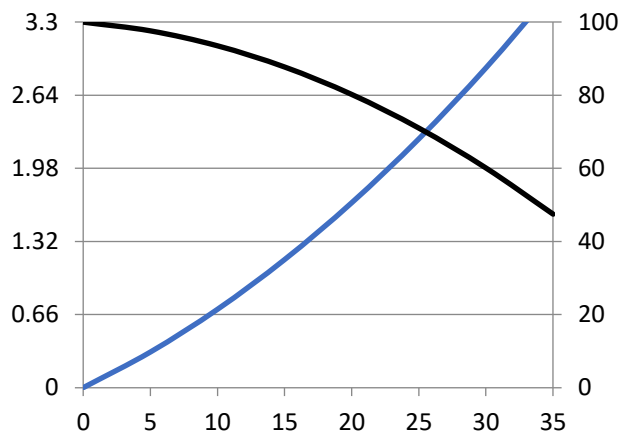

Inductance and temperature rise vs. current

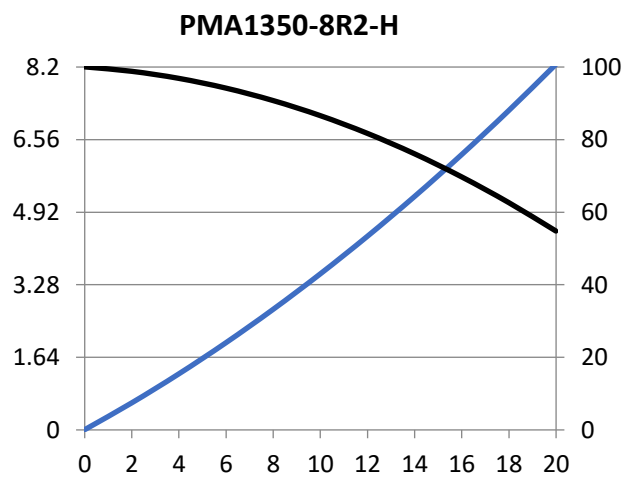
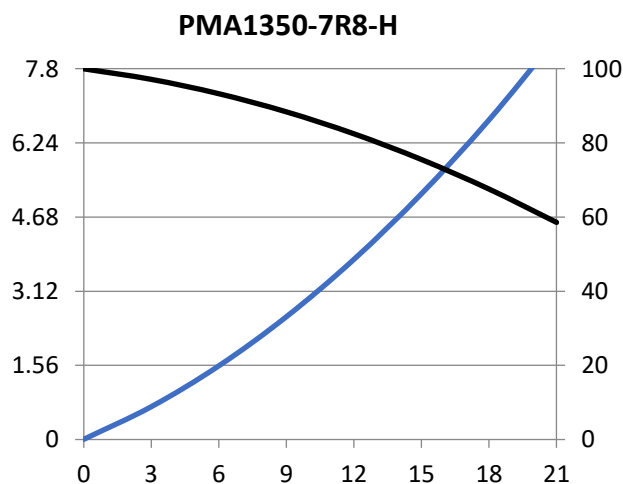
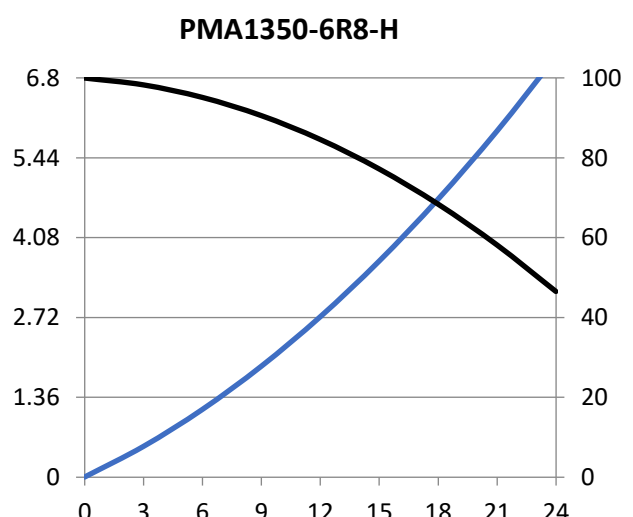
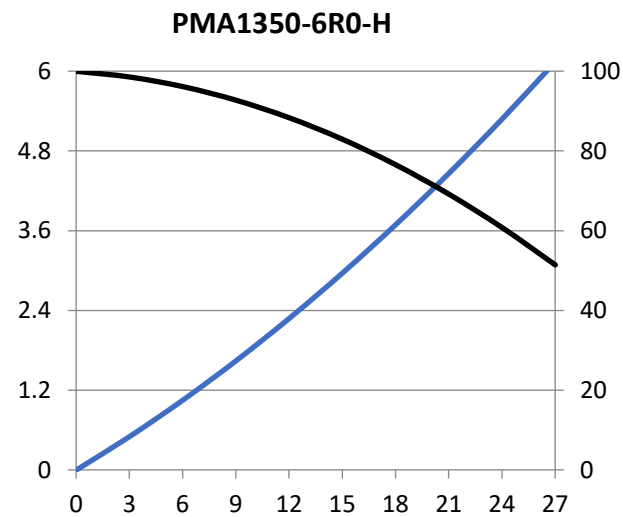
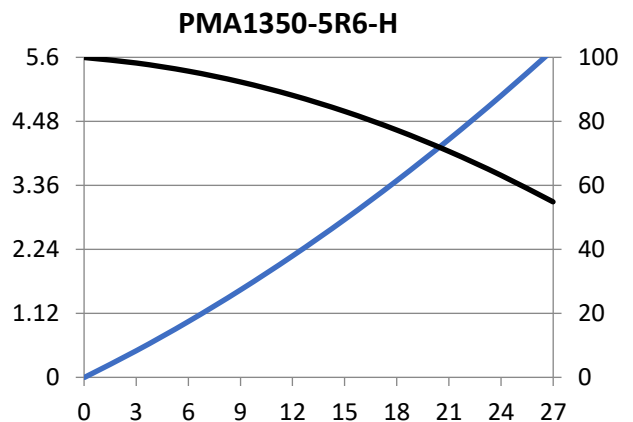
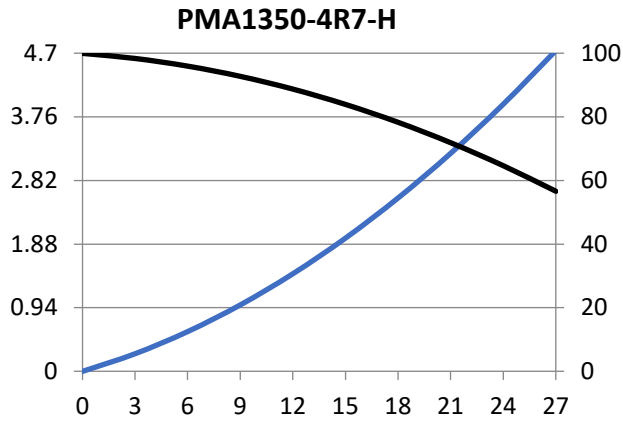

Inductance and temperature rise vs. current

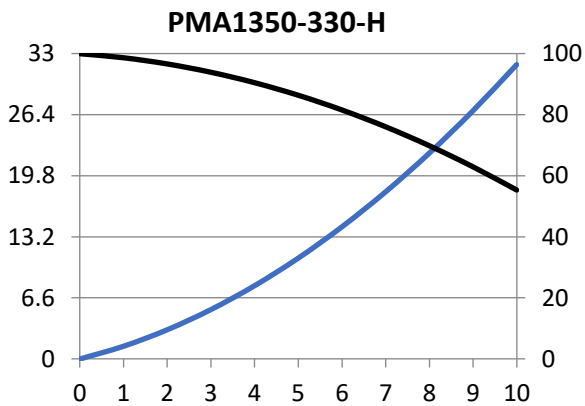
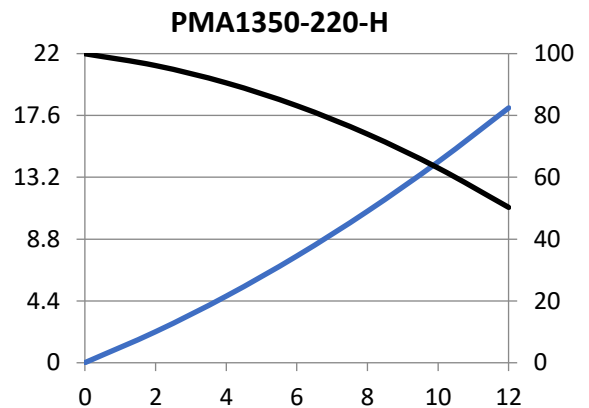
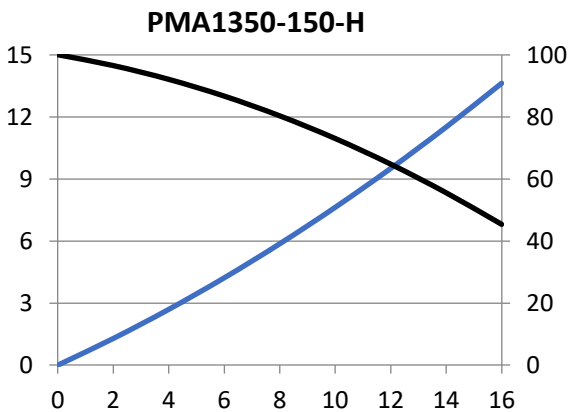
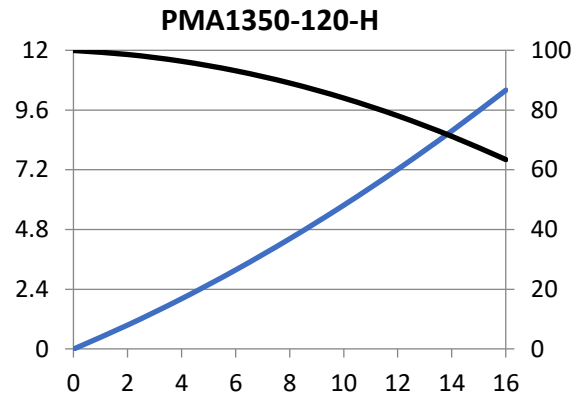
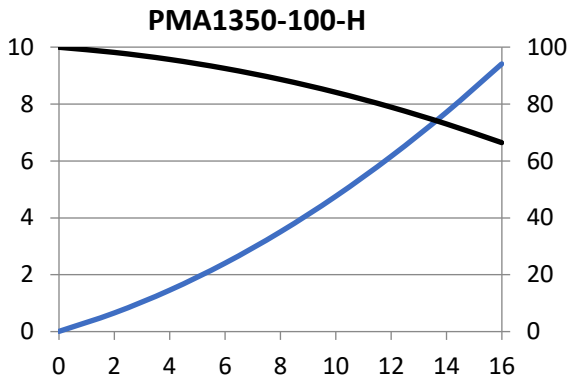

Legend

- Inductance
- Temperature rise

X-axis: I_{DC} (A)
 Y-axis (primary): Inductance (μH)
 Y-axis (Secondary): Temperature rise (°C)

Test Condition

Temperature: $25 \pm 2^\circ\text{C}$
 Humidity: < 70% RH
 Frequency: 100 KHz, 1.0V

Mechanical Reliability

Item	Specification and Requirement	Test Method
Solderability	The surface of terminal immersed shall be minimum of 95% covered with a new coating of solder	Solder heat proof: 1. Precondition: 8 hours steam aging 2. Retention time: 255 ± 5 °C for 5 ± 0.5 seconds
Vibration	Inductance change: Within $\pm 10\%$ Without mechanical damage such as break	1. Vibration frequency:(10 Hz to 2000 Hz) 2. Vibration time:Each four hours (12 times) in X, Y, Z direction: 12 hours in total 3. Amplitude: 1mm or 10 G
Shock	Inductance change: Within $\pm 10\%$ Without mechanical damage such as break	1. Peak value: 100 G 2. Duration of pulse: 6ms 3. Waveform: Half-sine Shocks; 3 times in X, Y, Z direction, 9 times in total

Endurance Reliability

Item	Specification and Requirement	Test Method
Thermal Shock	Inductance change: Within $\pm 10\%$ Without distinct damage in appearance	1. Repeat 1000 cycles as follow: (-55 ± 2 °C; 30 ± 3 min) → ($+155 \pm 2$ °C, 30 ± 3 min) change over time of temperature: ≤ 10 s 2. Recovery: $24 + 4 / -0$ hours of recovery under the standard condition after the test.
High Temperature & Humidity	Inductance change: Within $\pm 10\%$ Without distinct damage in appearance	$85^{\circ}\text{C}85\%\text{RH}$, Duration: $240+4/-0$ hours
Operational Life	Inductance change: Within $\pm 10\%$ Without distinct damage in appearance	1. Rated current (Idc) Environment condition: 85 °C 2. Duration: $1000 + 4 / -0$ hours
Low Temperature Store	Inductance change: Within $\pm 10\%$ Without distinct damage in appearance	Store temperature: -55 ± 2 °C, $1000 + 4 / -0$ hours
High Temperature Store	Inductance change: Within $\pm 10\%$ Without distinct damage in appearance	Store temperature: $+155 \pm 2$ °C, $1000 + 4 / -0$ hours

Dimensions

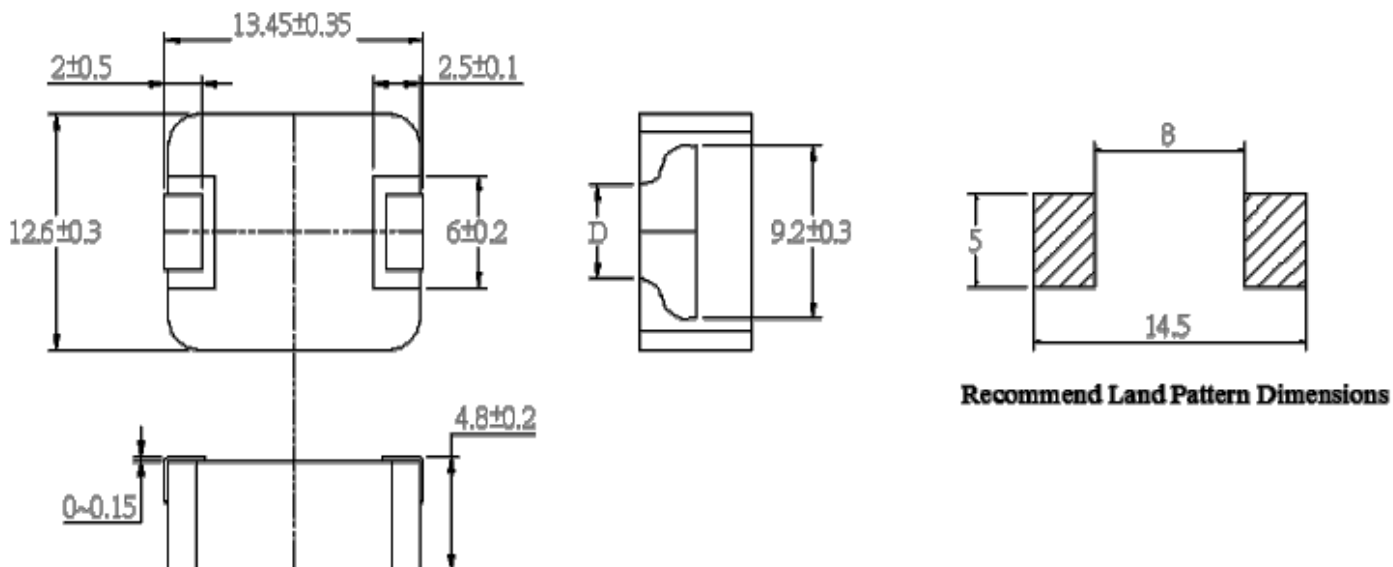

Code	Dimensions	
	0.1~2.2 μ H	3.3~33.0 μ H
D	3.68 ± 0.3	4.8 ± 0.3

Note : Dimensions in mm

Marking

The inductor is marked with a 3-digit code
 Example for 1.0 μ H it will be marked as 1R0
 Note : Using laser for marking

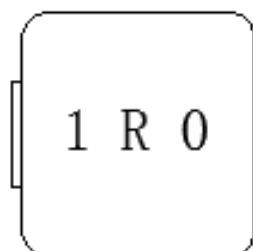

Tape Packaging Dimensions

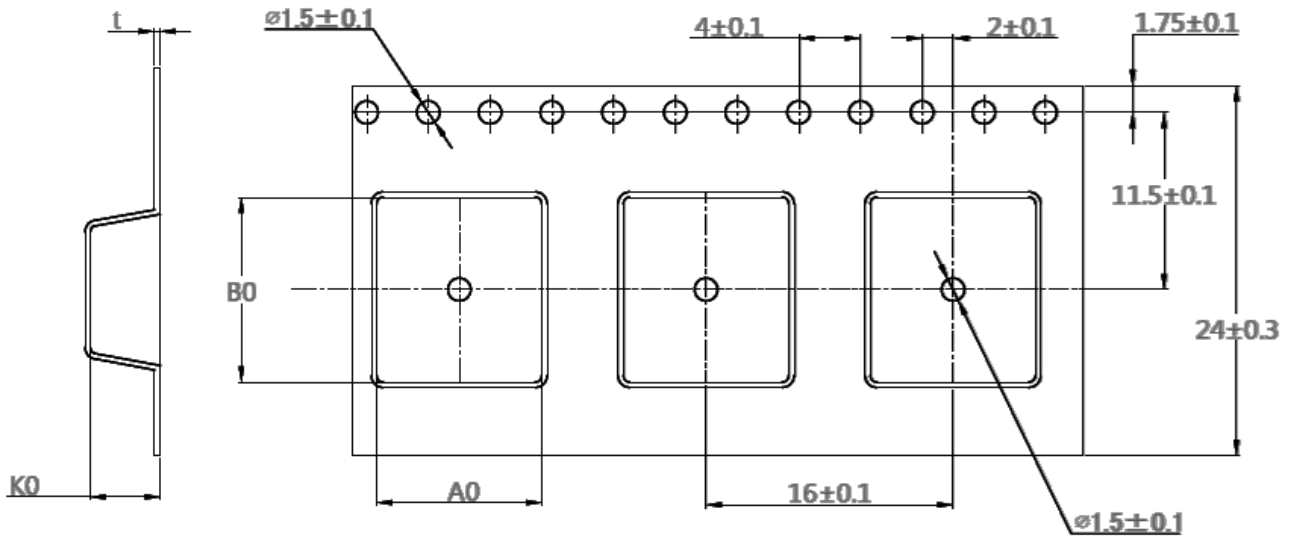

A0	B0	K0	t
13.4 ± 0.10	14.4 ± 0.10	5.4 ± 0.15	0.5 ± 0.05

Reel Dimensions

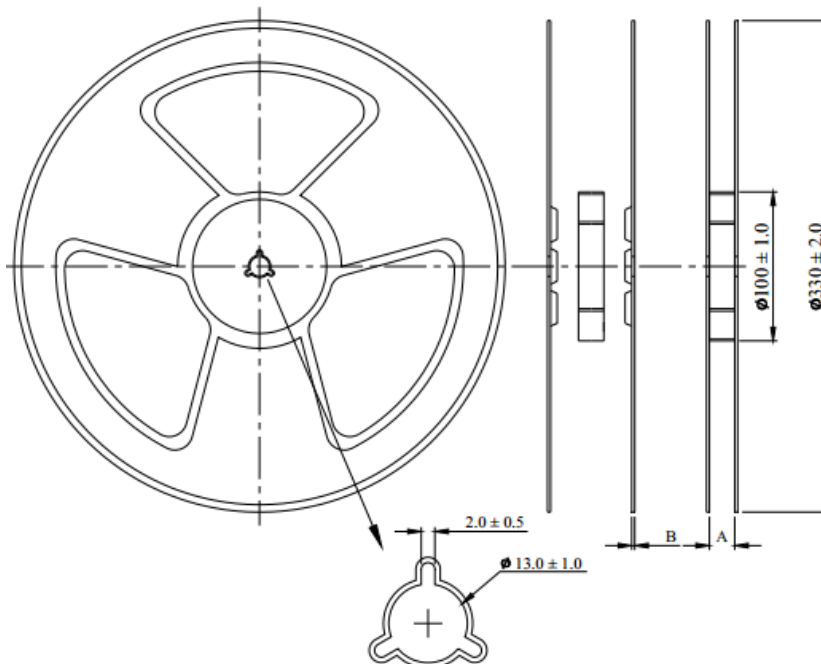

	A	B
mm	24.5 ± 0.2	2.0 ± 0.2

Peel force of top cover tape

The peel speed shall be about 300mm/minute

The peel force of top cover tape shall be between 0.1 to 1.3 N

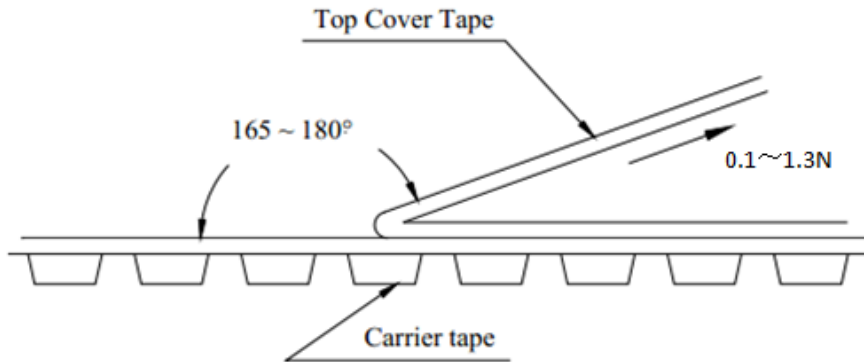

Numbers of taping

500 pieces/reel



ANDEX - Jan 2000 - All rights reserved
For more information on ANDEX products and solution,
visit www.Andextek.com.